

Uncertainties in workplace external dosimetry

A Monte Carlo approach

Janwillem van Dijk
NRG-RE
EURADOS annual meeting 2006

J.W.E. van Dijk
NRG-Radiation and Environment
P.O. Box 9034 ES, Arnhem, The Netherlands
j.vandijk@nrg-nl.com

Janwillem van Dijk EURADOS AM2006 1



Scope of the presentation

Evaluating the

- **combined standard uncertainty and**
 - **coverage interval at 95% coverage probability**
- using type-test data

**Only showing
general ideas**

Example:

- **TLD photon dosimeter NRG-Arnhem**
Type-test results from joined project
NRPB-RISØ-TNO (Villigen workshop 1993)



Uncertainty evaluation of personal dosemeters using numerical methods

- 1. Introduction
- 2. Ingredients
- 3. Measurement model
- 4. Uncertainty evaluation 1 detector
- 5. Uncertainty evaluation 2 detectors
- 6. Uncertainty evaluation with background
- 7. Summary and conclusions

Uncertainty evaluation using GUM

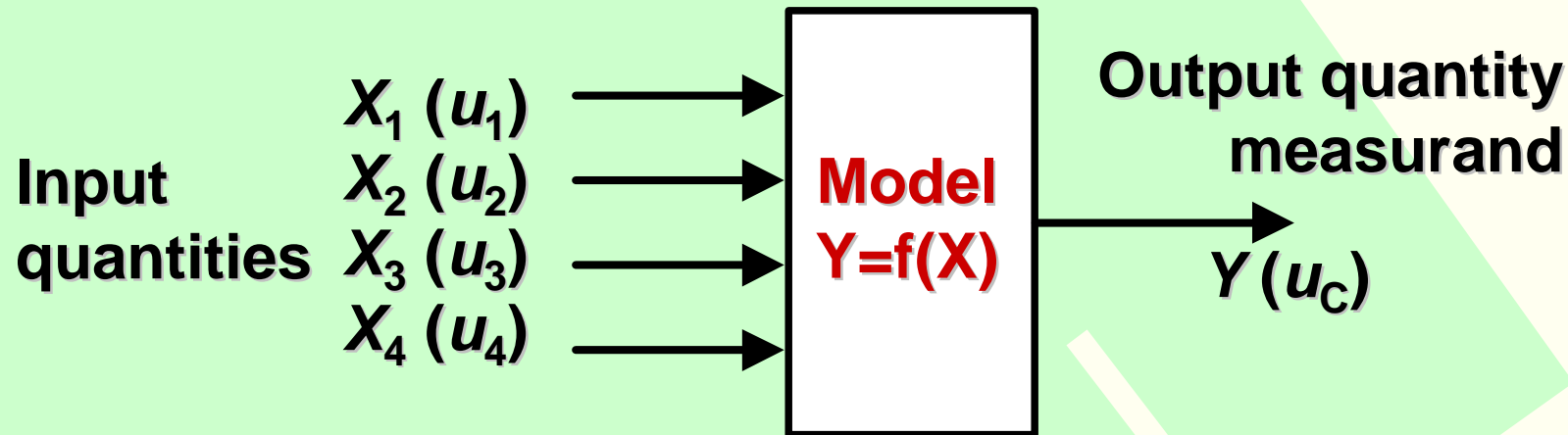

Evaluating the propagation of uncertainties from input quantities to measurand

- 1) Analytical methods
- 2) Law of Propagation of Uncertainty, LPU
- 3) Numerical methods

Numerical methods based on Monte Carlo simulation

- Arbitrary PDFs for X_i can be used
- Non-linear or discontinuous $f(X)$ allowed (no sensitivity coefficients needed)
- Input quantities can be correlated (coverage interval directly evaluated)
- No need for knowing degrees of freedom

Mathematical analysis and approximations are replaced by

brute computing power

Uncertainty evaluation of personal dosemeters using numerical methods

1. Introduction
- 2. Ingredients
3. Measurement model
4. Uncertainty evaluation 1 detector
5. Uncertainty evaluation 2 detectors
6. Uncertainty evaluation with background
7. Summary and conclusions

Type test of TLD NRG-Arnhem

Joint NRPB-RISØ-TNO experiment 1991

Response

15 energies

4 angles

3 dosimeters per E, α

2 TLDs per dosimeter

360 measurements

B detector 3 mm PC

D detector 2 mm Al

Energy (keV)	Angle			
	0°	20°	40°	60°
17.4	0.084	0.062	0.030	0.012
17.4	0.077	0.076	0.035	0.018
17.4	0.069	0.060	0.029	0.010
23.1	0.455	0.403	0.322	0.162
23.1	0.470	0.406	0.308	0.153
23.1	0.452	0.410	0.297	0.146
....
....
....
662	1.138	1.189	1.103	1.143
662	1.111	1.158	1.156	1.113
662	1.161	1.143	1.146	1.112
1250	0.982	1.000	1.081	1.041
1250	0.983	1.003	1.012	1.029
1250	1.035	0.984	0.991	1.024



Type test of TLD NRG-Arnhem



AN ECN KEMA COMPANY

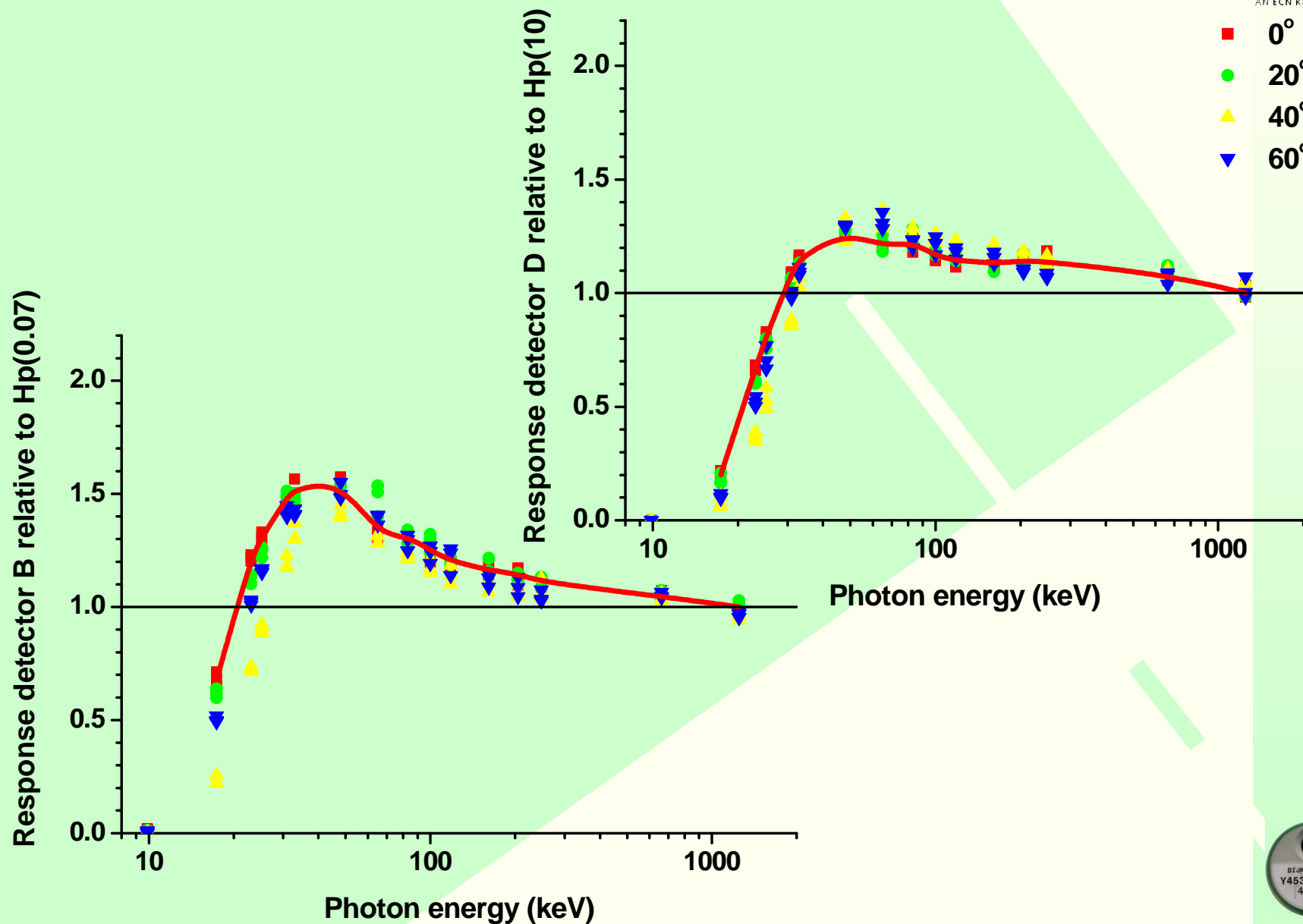

Janwillem van Dijk EURADOS AM2006 8



Uncertainty evaluation in EUR 14852 and IAEA RS-G-1.3

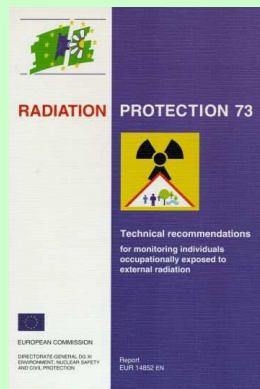

- U_A Type A uncertainty (e.g. noise)
- $U_{B(E,\alpha)}$ Type B uncertainty
 - from energy and direction
- $U_{B(other)}$ - from all other sources

Response averaged over angles

$$R_{E_i\bar{\alpha}} = \frac{1}{4} (R_{E_i,0} + R_{E_i,20} + R_{E_i,40} + R_{E_i,60})$$

$$u_{B(E,\alpha)} = \text{Max}_{E_N}^{E_1} |1 - R_{E_i\bar{\alpha}}| / 1.96$$

Combined relative standard uncertainty

$$u_C = \sqrt{u_A^2 + u_{B(E,\alpha)}^2 + u_{B(other)}^2} \approx 0.27$$

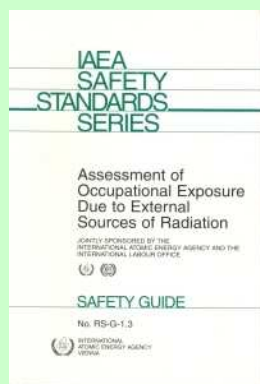

Spectral distributions of workplace fields

Weighted average of NRG customers

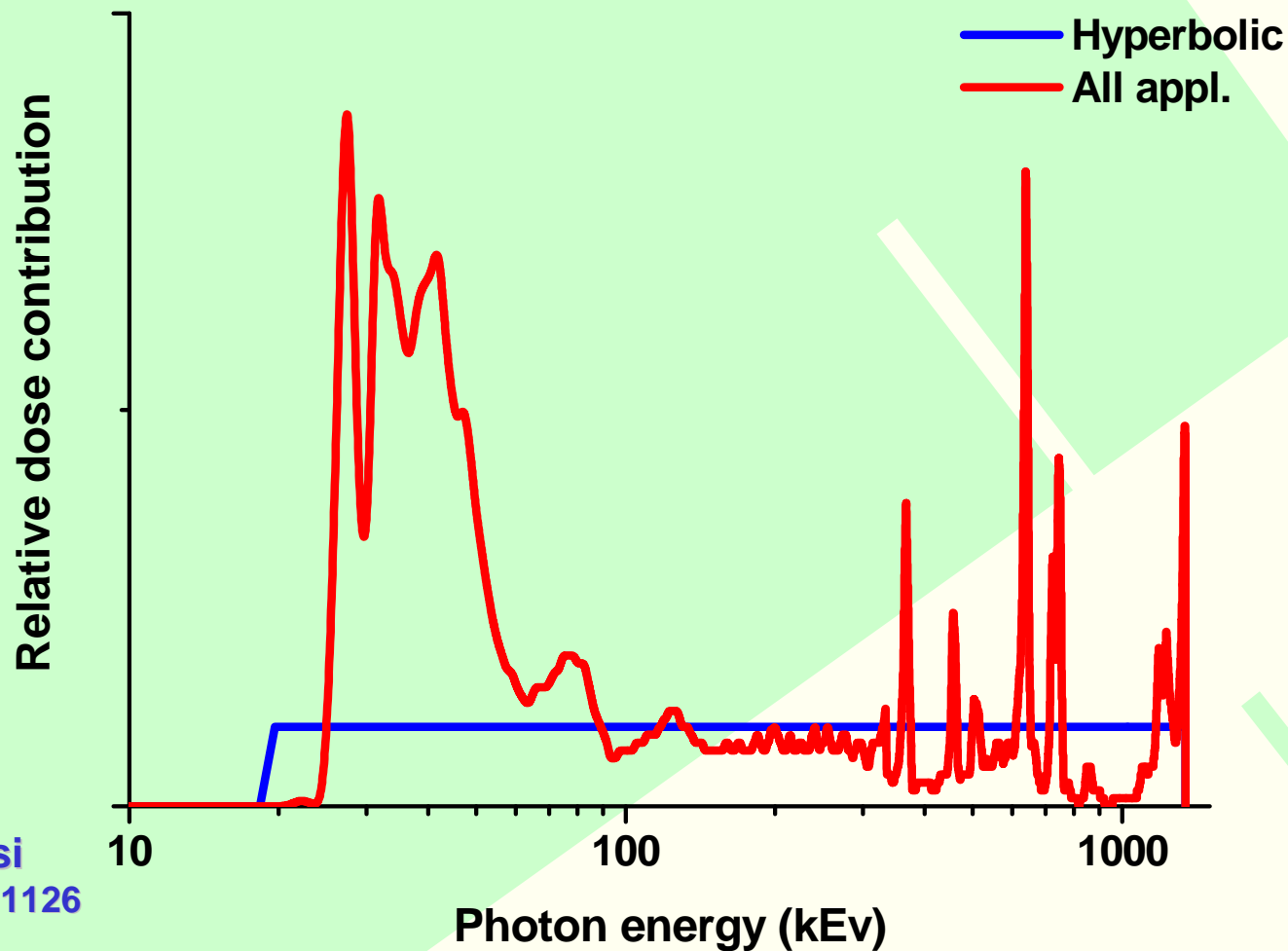

Peter Ambrosi
IAEA TECDOC 1126



Janwillem van Dijk EURADOS AM2006 10



Uncertainty evaluation of personal dosemeters using numerical methods

1. Introduction
2. Ingredients
- 3. Measurement model
4. Uncertainty evaluation 1 detector
5. Uncertainty evaluation 2 detectors
6. Uncertainty evaluation with background
7. Summary and conclusions

Input quantities of dose measurement

- Indicated value
- Calibration factor under reference conditions
- Correction factor for:
 - signal fading
 - radiation energy and direction
 - dose rate
 - non-linearity
 - natural background
 -
 - supply voltage
 - temperature and humidity
 - electromagnetic disturbances
 - shock and vibration
 -

Schematic input-output model for 1 detector TLD

Input quantities

- X_1 , PM signal
- X_2 , Zero signal
- X_3 , Detector sensitivity
- X_4 , Reader sensitivity
- X_5 , Fading parms
- X_6 , Time readouts
- X_7 , Background dose rate
- X_8 , Photon energy
- X_9 , Angle of incidence

Output quantity measurand

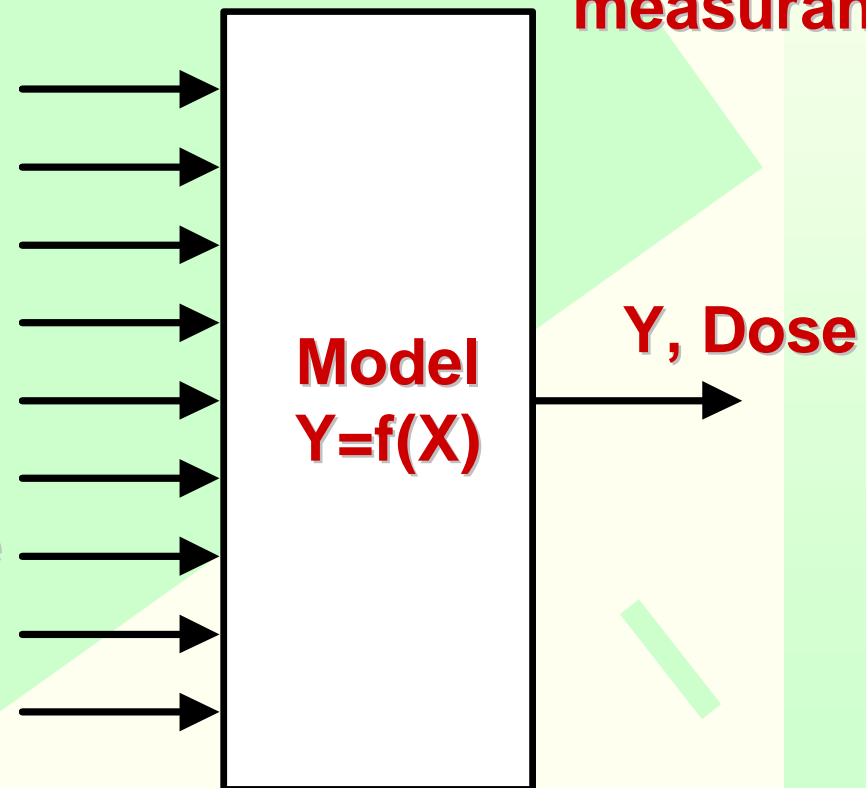

Course of events for the numerical method

- 1) Generate for each input quantity X_i : random value x_i based on the probability density function (pdf) of that quantity**
- 2) Calculate the output quantity**
- 3) Repeat steps 1 and 2 e.g. 100,000 times**
- 4) Repeat steps 1 and 2 e.g. 100,000 times**
- 5) Make a statistical analysis of the results**

Bootstrapping

Uncertainties caused by variation in

- Individual TL-detector properties
- Zero signal
- Reader noise

Are taken into account by using randomly one of three dosimeters

Bootstrapping

The re-use of measurement data for evaluating uncertainty and confidence limits

Energy (keV)	Angle			
	0°	20°	40°	60°
17.4	0.084	0.062	0.030	0.012
17.4	0.077	0.076	0.035	0.018
17.4	0.069	0.060	0.029	0.010
23.1	0.455	0.403	0.322	0.162
23.1	0.470	0.406	0.308	0.153
23.1	0.452	0.410	0.297	0.146
....
....
....
662	1.138	1.189	1.103	1.143
662	1.111	1.158	1.156	1.113
662	1.161	1.143	1.146	1.112
1250	0.982	1.000	1.081	1.041
1250	0.983	1.003	1.012	1.029
1250	1.035	0.984	0.991	1.024



Uncertainty evaluation of personal dosemeters using numerical methods

1. Introduction
2. Ingredients
3. Measurement model
- 4. Uncertainty evaluation 1 detector
5. Uncertainty evaluation 2 detectors
6. Uncertainty evaluation with background
7. Summary and conclusions

Uncertainty evaluation of dosemeter with one detector

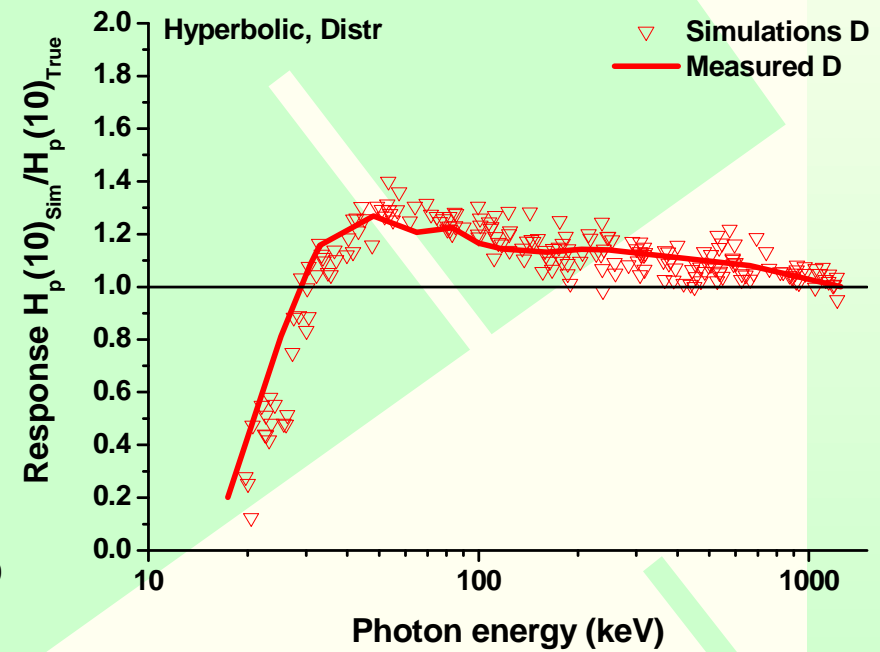
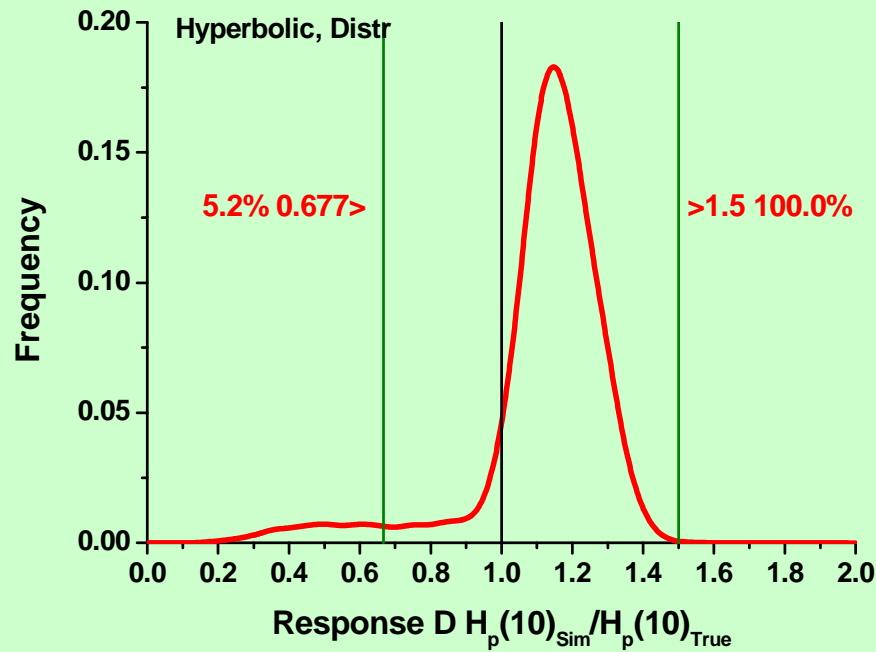

$u_C = 19\%$



Uncertainty evaluation of dosemeter with one detector

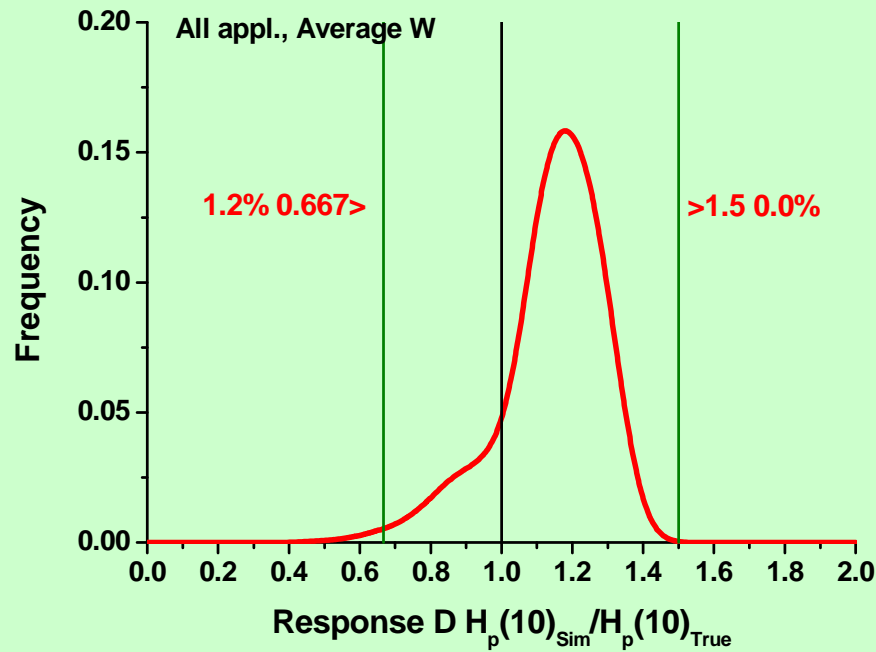

$u_C=14\%$

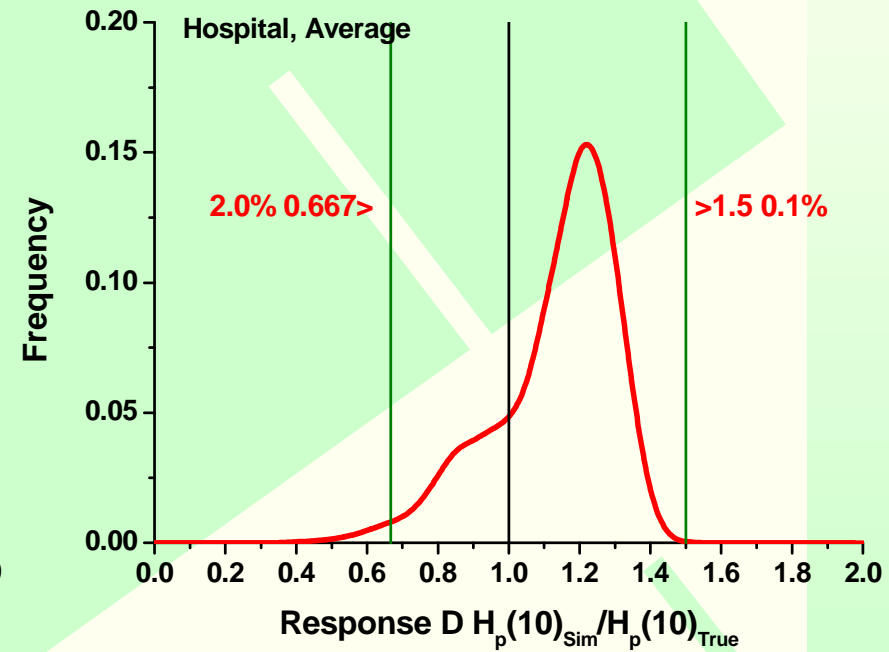

$u_C=16\%$

Uncertainty evaluation of personal dosemeters using numerical methods

1. Introduction
2. Ingredients
3. Measurement model
4. Uncertainty evaluation 1 detector
- 5. Uncertainty evaluation 2 detectors
6. Uncertainty evaluation with background
7. Summary and conclusions

Algorithm for energy correction

Y_1 3 mm plastic, Y_2 2 mm Al

Calculate ratio $Q = Y_1 / Y_2$

If $Q > 1$

Use linear interpolation in type-test table to find corresponding responses R_1 and R_2

$$Y_{\text{Corr}} = 0.5(Y_1/R_1 + Y_2/R_2)$$

Else

no correction

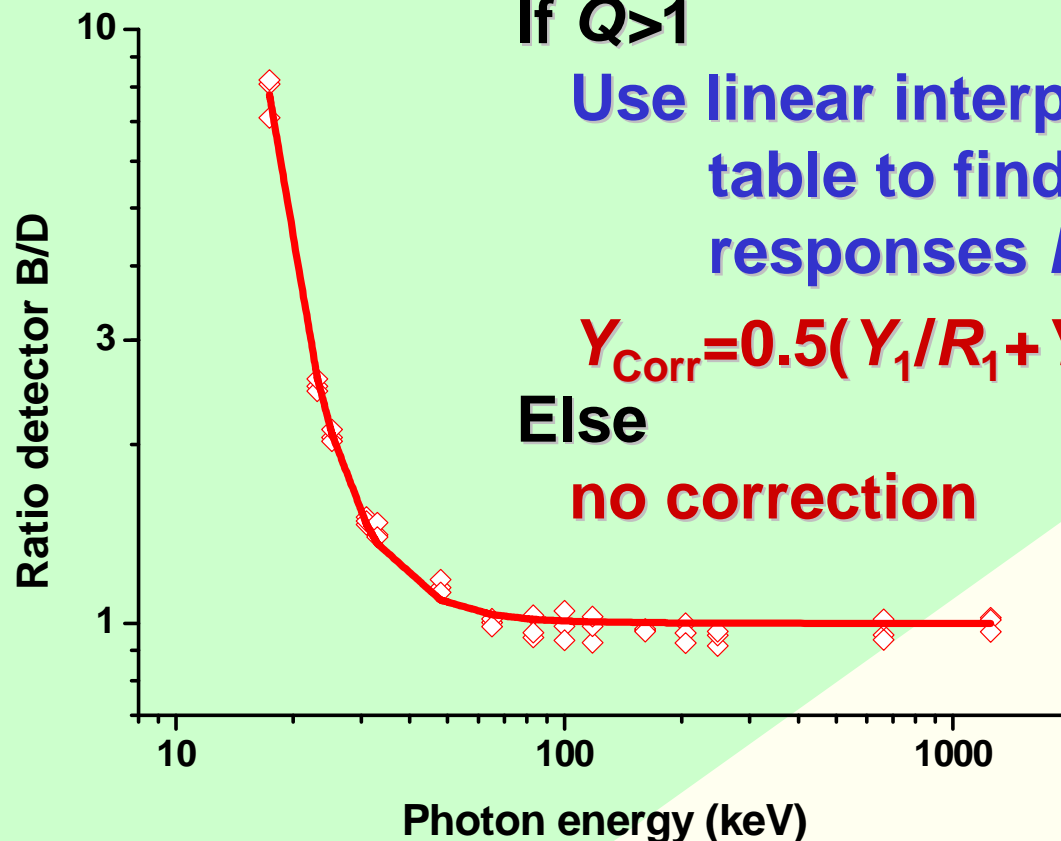

Effect of energy correction on type-test results

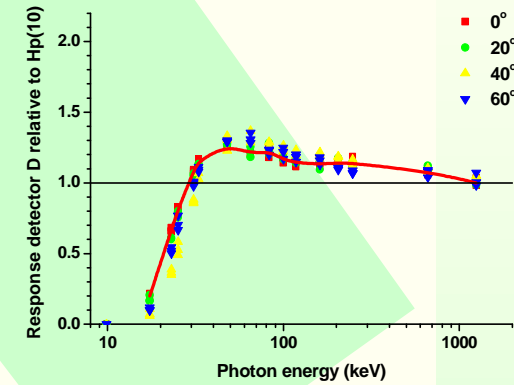
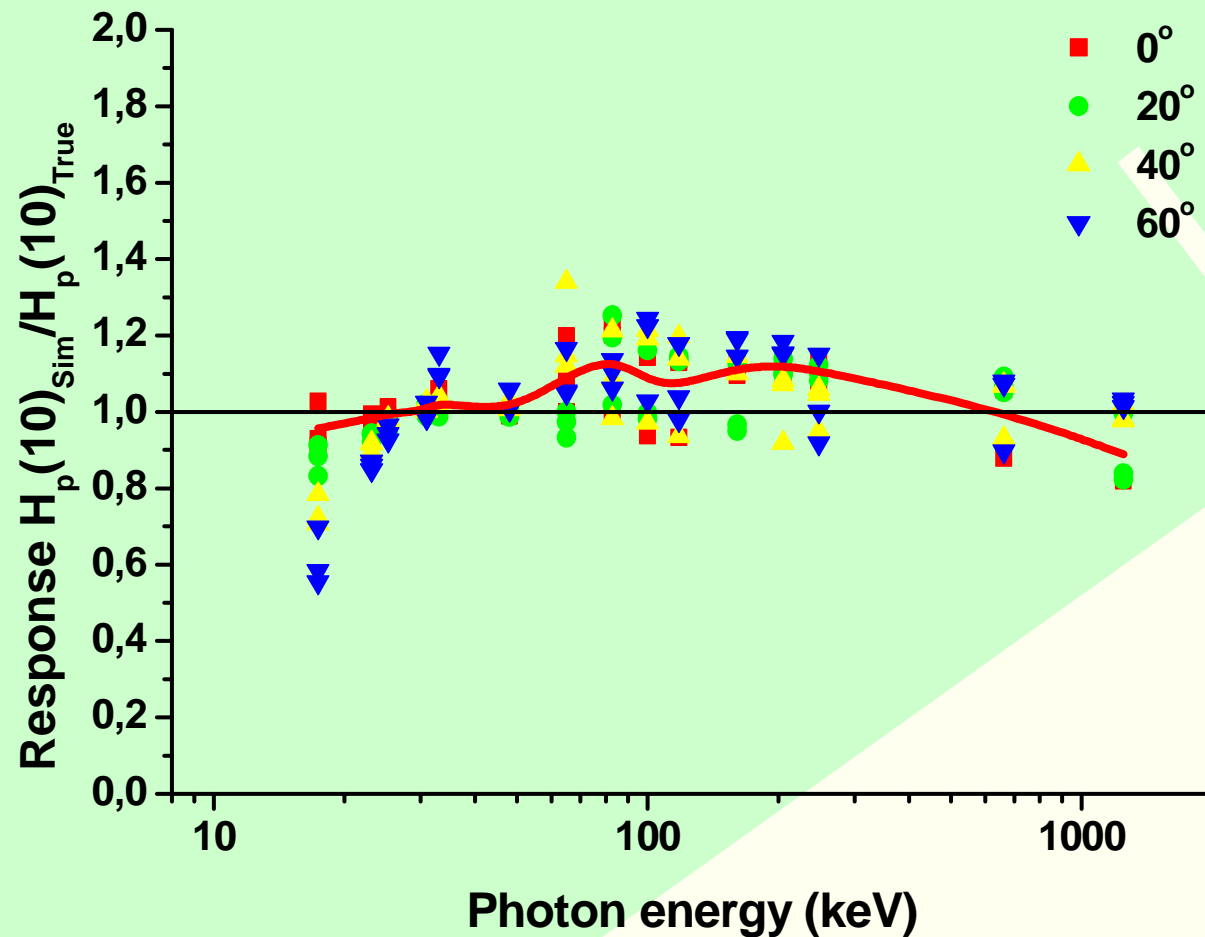

Schematic input-output model component for energy correction

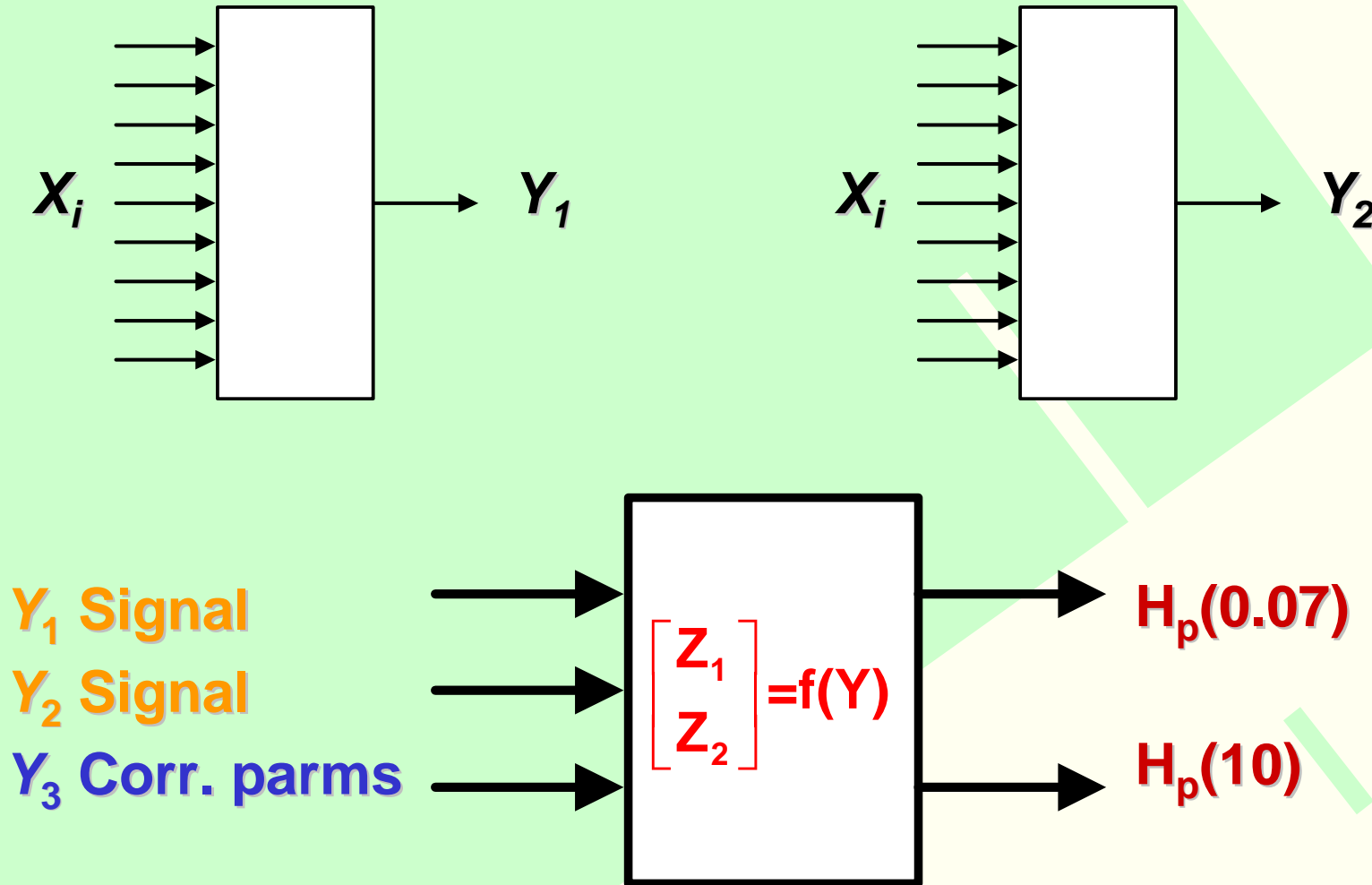

Effect of energy correction on simulations

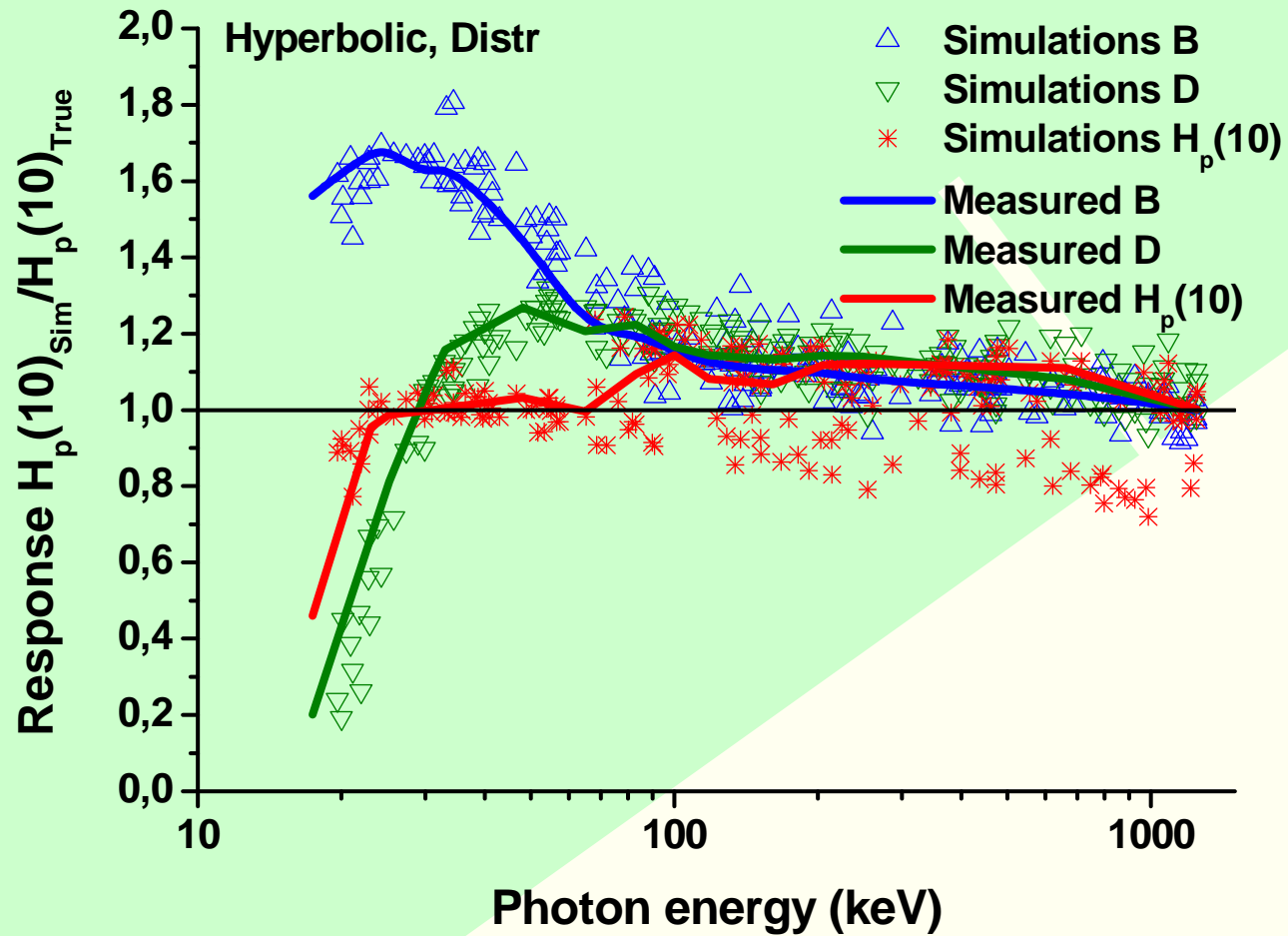

Effect of energy correction on uncertainty and confidence limits

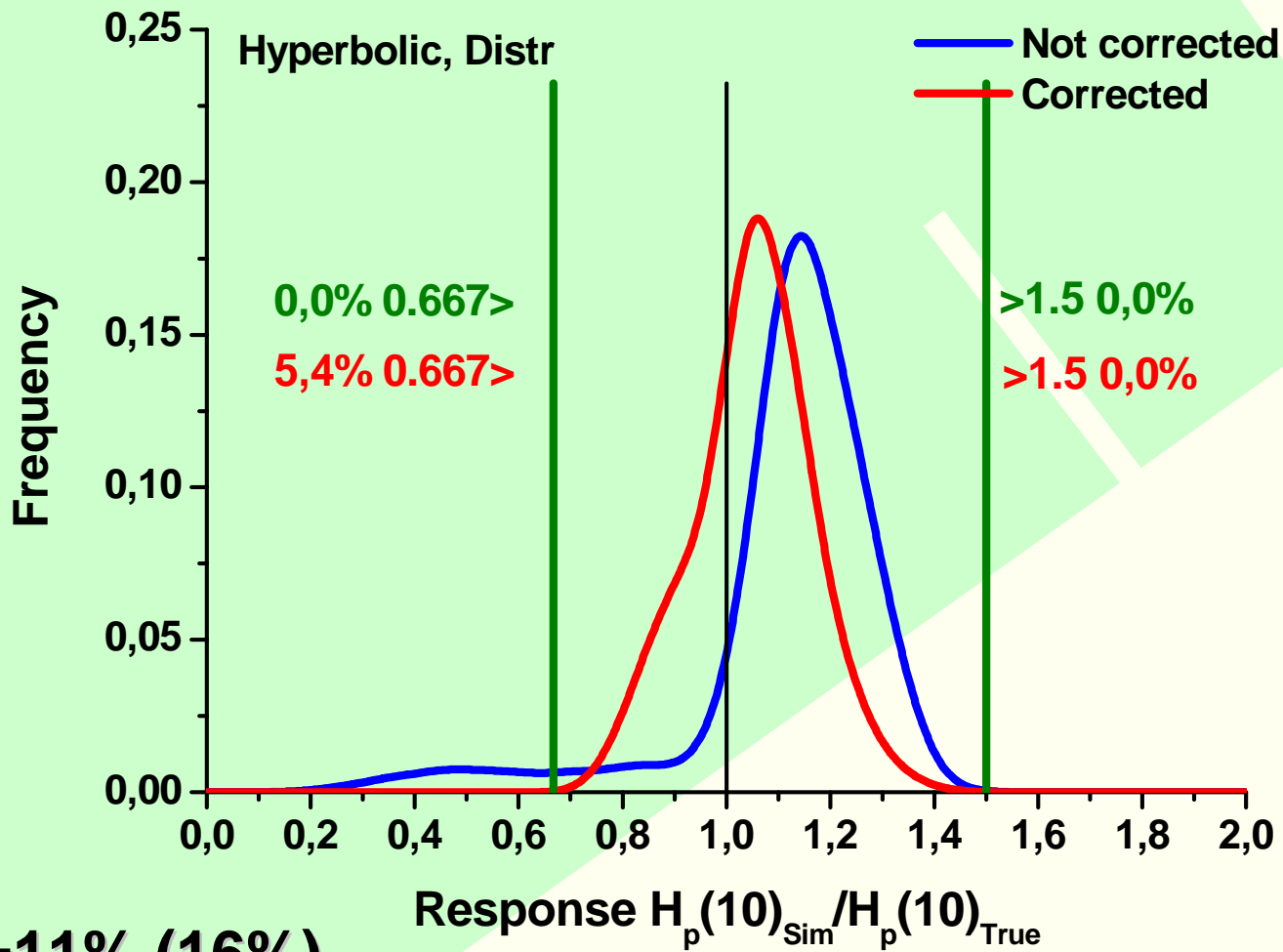

$u_C = 11\% (16\%)$



Effect of energy correction on uncertainty and confidence limits

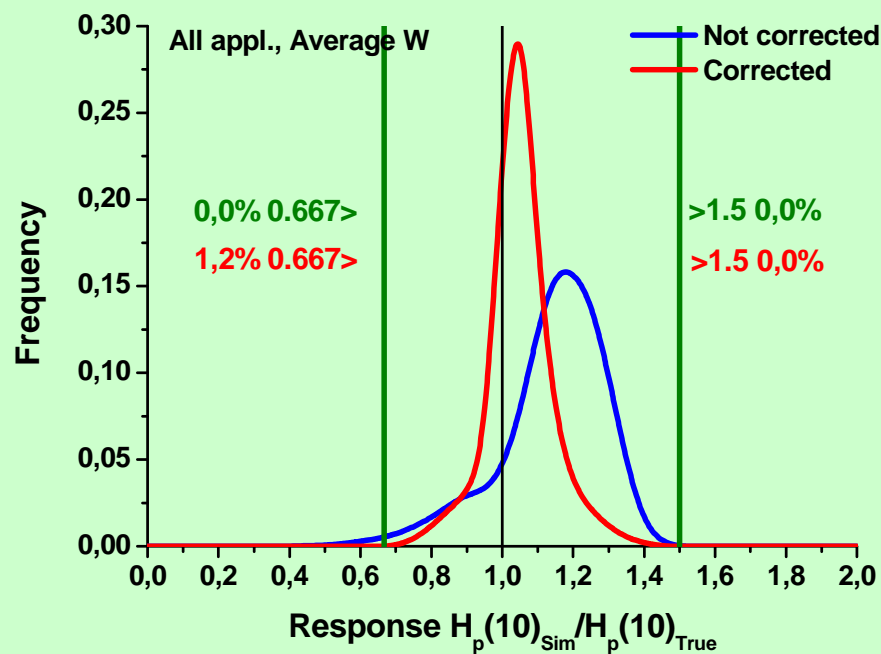

$u_C = 9\%$ (15%)

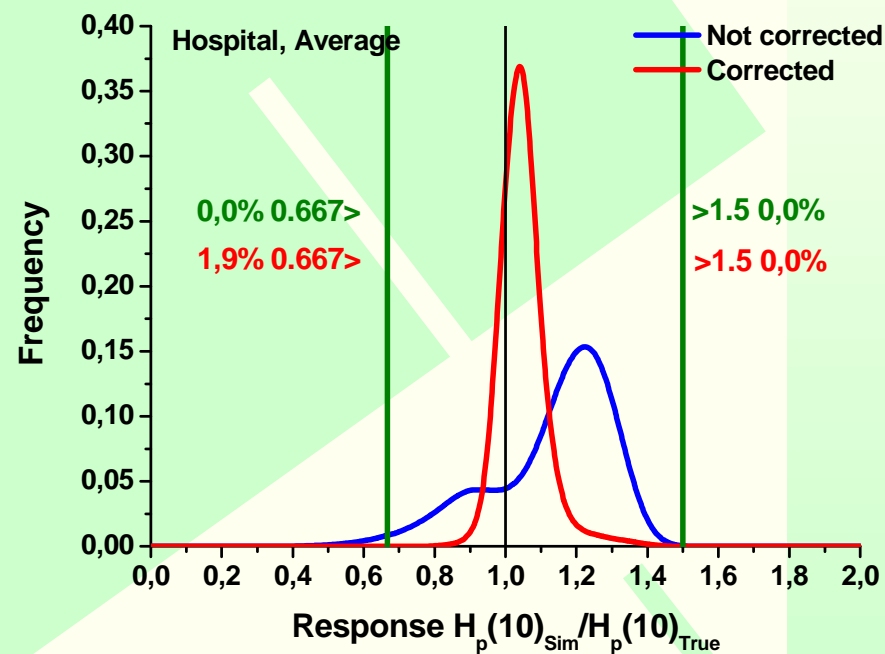

$u_C = 6\%$ (17%)



Effect of energy correction on uncertainty and confidence limits

Average 100 exposures

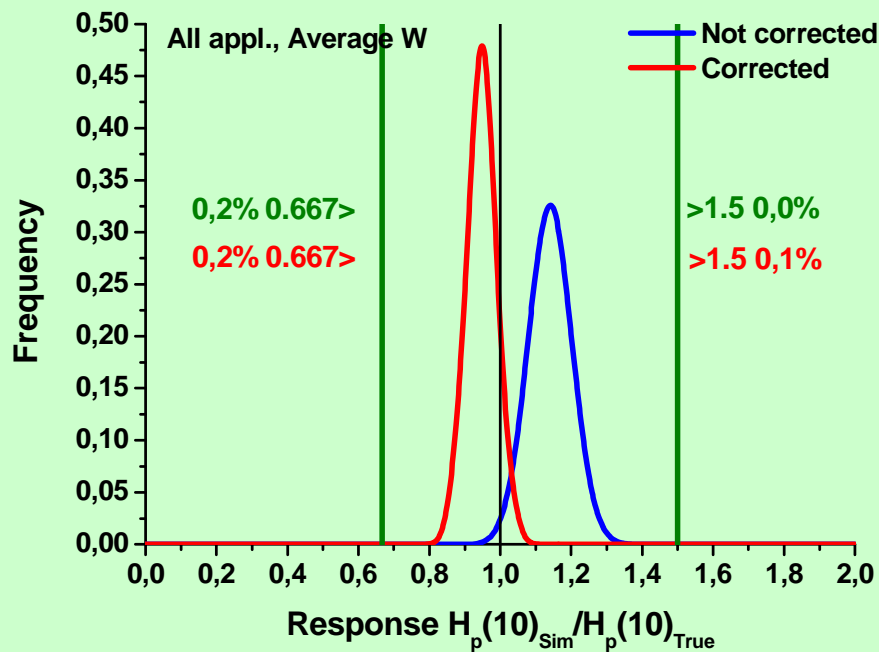

$u_C = 3\%$ (5%)

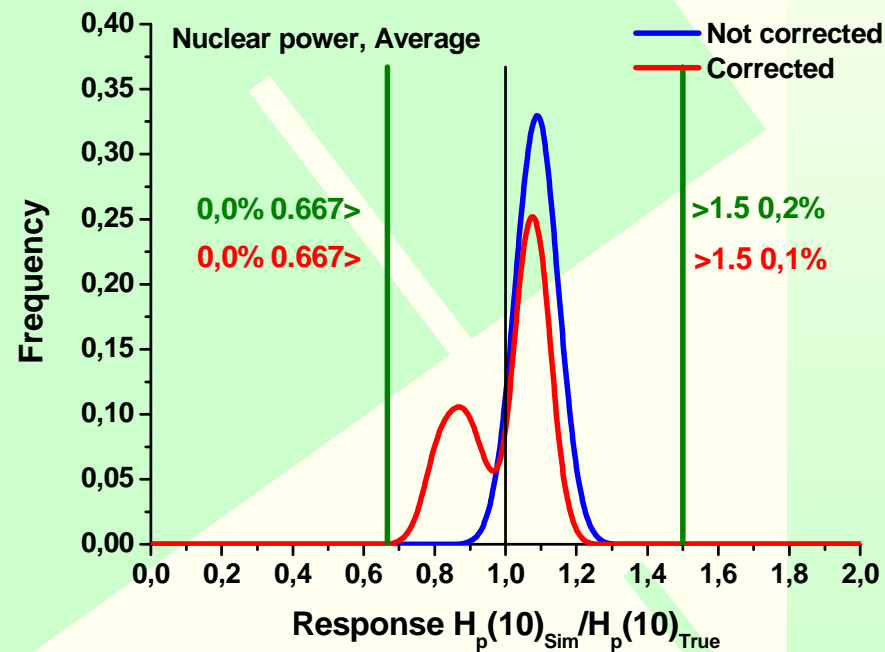

$u_C = 11\%$ (5%)



Uncertainty evaluation of personal dosemeters using numerical methods

1. Introduction
2. Ingredients
3. Measurement model
4. Uncertainty evaluation 1 detector
5. Uncertainty evaluation 2 detectors
- 6. Uncertainty evaluation with background
7. Summary and conclusions

Distribution of the natural background in the Netherlands

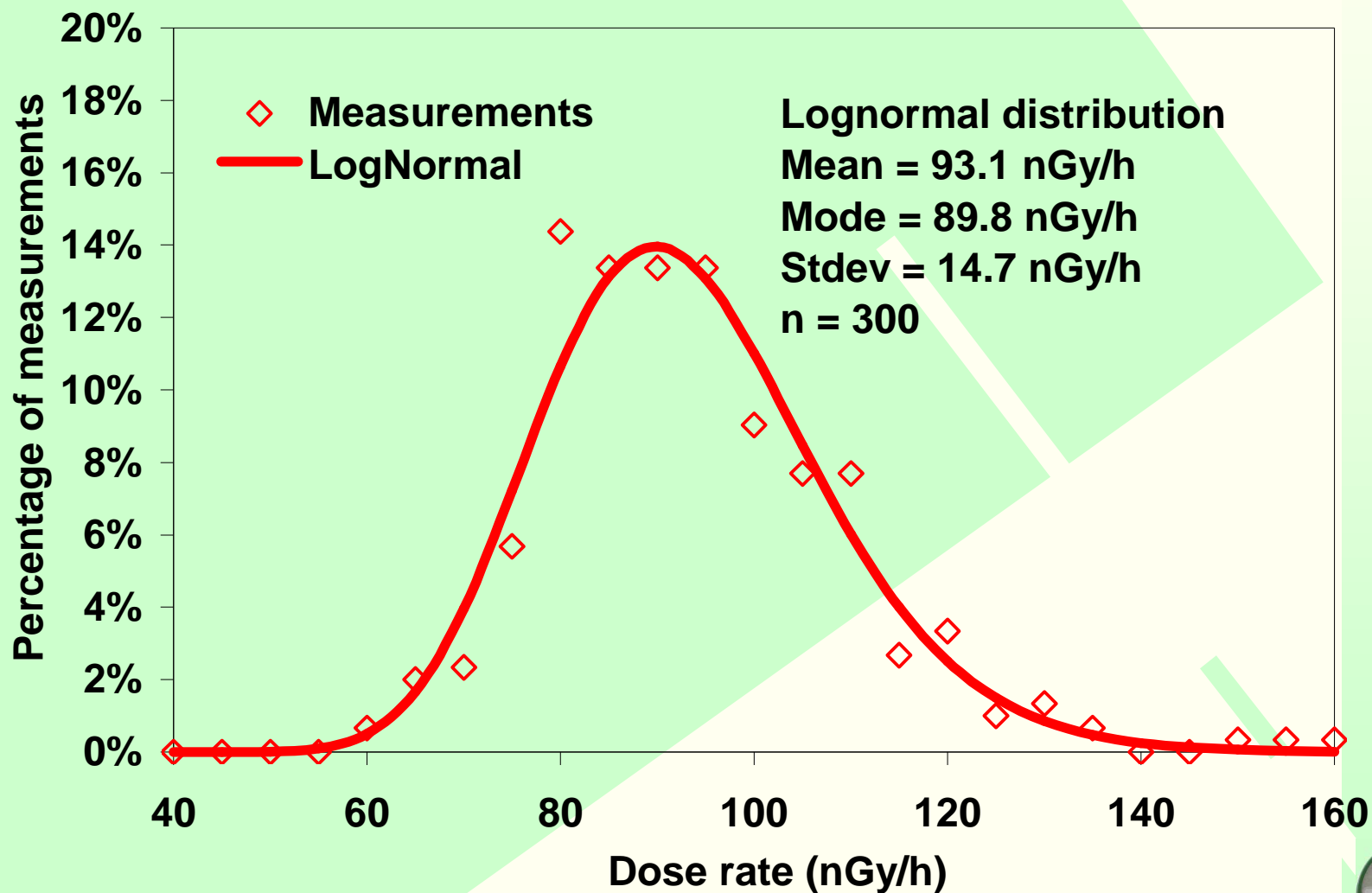

Monte Carlo simulation

Effect of background subtraction

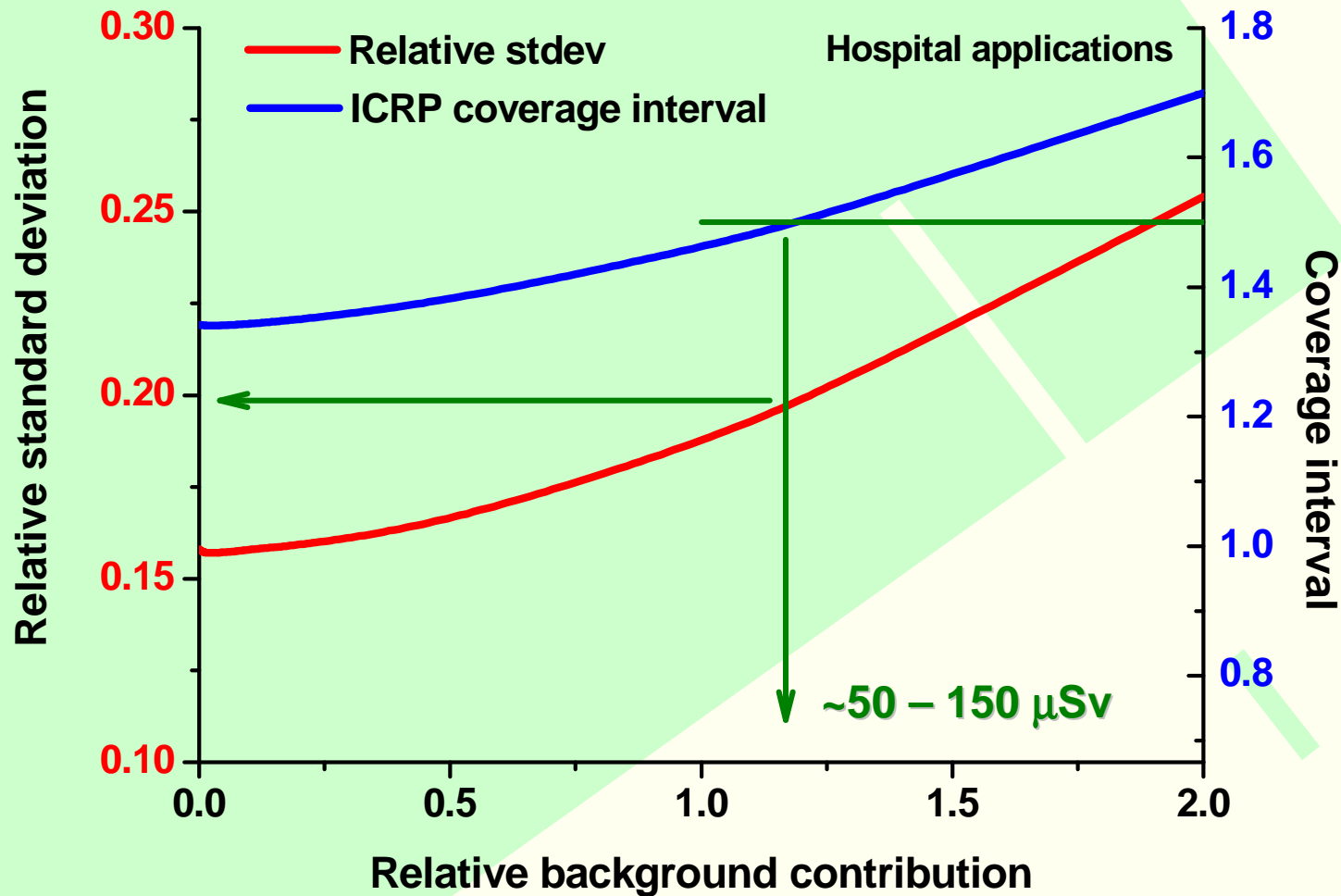

Uncertainty evaluation of personal dosemeters using numerical methods

1. Introduction
2. Ingredients
3. Measurement model
4. Uncertainty evaluation 1 detector
5. Uncertainty evaluation 2 detectors
6. Uncertainty evaluation with background
- ➔ 7. Summary and conclusions

Evaluating standard uncertainty using Monte Carlo simulation

Do type test
Define distributions
Do Monte Carlo simulations



Combined standard uncertainty
Coverage interval

Evaluating standard uncertainty using Monte Carlo simulation

Do Monte Carlo sampling N_{sim} times

Average response $\bar{R}_{sim} = \frac{\sum_{i=1}^{N_{sim}} R_{sim,i}}{N_{sim}}$

Combined relative standard uncertainty

$$u_c \leftarrow s = \sqrt{\frac{\sum_{i=1}^{N_{sim}} (R_{sim,i} - \bar{R}_{sim})^2}{N_{sim} - 1}}$$

Evaluating standard uncertainty using Monte Carlo simulation

Sort simulation results

Then for e.g. 100,000 simulations the interval of 95% coverage probability ranges from

$$R_{sim, 2500} \text{ to } R_{sim, 97,500}$$

The asymmetric ICRP coverage interval is easily calculated

$$\frac{1}{1.5} < R_{sim} < 1.5$$

Evaluating standard uncertainty using Monte Carlo simulation

	not corrected		Corrected	
	u_c	Coverage interval (95%)	u_c	Coverage interval (95%)
20<E<1350				
EUR 14852	27%	0.47-1.53	15%	0.82-1.18
Hyperbolic	19%	0.60-1.40	11%	0.78-1.23
All PTB	14%	0.76-1.30	9%	0.81-1.22
Hospital PTB	16%	0.72-1.29	6%	0.91-1.14
NPP PTB	7%	0.92-1.20	12%	0.73-1.15

Evaluating standard uncertainty using Monte Carlo simulation

Monte Carlo based numerical methods

Allow to evaluate the

- **combined standard uncertainty**
 - **coverage interval (also asymmetric)**
- using observed distributions

Evaluating standard uncertainty using Monte Carlo simulation

Monte Carlo based numerical methods

Reduce the need for using

- assumptions on distributions
- approximations of analytical functions
- determination of sensitivity coefficients

No need for worries about

- correlation between input quantities
- degrees of freedom for coverage calculation

Evaluating standard uncertainty using Monte Carlo simulation

Computer programming is simple using well established algorithms

Methods can be defined precisely and made suitable for approval criteria

Simulation time 1-10 seconds depending on
shape of distributions
number of input quantities
number of samples and
processor power

Evaluating standard uncertainty using Monte Carlo simulation

Numerical methods are transparent, powerful and a valuable *addition* to the tools available for uncertainty analysis

**LPU,
sensitivity coefficients,
degrees of freedom**



Uncertainties in workplace external dosimetry

A Monte Carlo approach

**Numerical methods can give
realistic estimates for
combined standard uncertainty !**

**Do some gambling and
your dosimeter might win**

Thank you